



**T230 MOTORIZED VIP 3K**

**OPERATION and MAINTENANCE MANUAL**

# TABLE OF CONTENTS

<b>BEFORE YOU START</b>	<b>3</b>
<b>TURNSTILE SAFETY INSTRUCTIONS</b>	<b>3</b>
<b>TURNSTILE USER INSTRUCTIONS</b>	<b>3</b>
<b>T230 MOTORIZED VIP 3KTURNSTILE TECHNICAL SPECIFICATIONS</b> <b>4</b>	
<b>T230 MOTORIZED VIP 3KTURNSTILE SYSTEM SPECIFICATIONS</b>	<b>5</b>
<b>POWER SUPPLY</b>	<b>5</b>
<b>T230 MOTORIZED VIP 3KTURNSTILE ASSEMBLY INSTRUCTIONS -1</b>	<b>6</b>
<b>T230 MOTORIZED VIP 3KTURNSTILE MATERIAL LIST</b>	<b>7</b>
<b>T230 MOTORIZED VIP 3KTURNSTILE ELECTRICAL CIRCUIT DIAGRAM</b>	<b>8</b>
<b>T230 MOTORIZED VIP 3KTURNSTILE -HOW TO RUN</b>	<b>9</b>

**T230 MOTORIZED VIP 3K TURNSTILE MAINTENANCE INSTRUCTIONS**  
**11**

**T230 3K TURNSTILE TROUBLESHOOTING**

**12**

# BEFORE YOU START

Thank you for purchasing T230 Motorized Vip 3K Turnstile. Please, carefully read the instructions contained in this manual for a long and smooth operation of the turnstile and keep the manual for future references.



## TURNSTILE SAFETY INSTRUCTIONS

- It is recommended to read all safety and maintenance instructions before installing and using the turnstile.
- Read the manual, before operating the turnstile.
- Do not open the turnstile, due to safety precautions. Any repairment must be done only by authorized services. Modifications made by user may result in danger for the turnstile and people.
- Do not operate damaged turnstiles and call an authorized service immediately.
- Comply with the power and voltage values specified in the technical specifications of turnstile.
- Comply with the operating temperature range specified in the technical specifications of turnstile.
- Check the power supply and control the card connections before re-energizing the turnstile afterwards any maintenance or damage.
- Use certificated spare parts and accessories approved and allowed by the producer.
- In any problem, cut off the electrical connections of the turnstile and call an authorized service.
- During the cleaning and maintenance, cut off the electrical connections. Otherwise damage to the parts may result.
- Use wet rag for cleaning.
- Keep the turnstile away from over heated or fire environment. Over heat may result in a damage to the turnstile.
- Do not use the turnstile in high magnetic areas.
- Do not expose the turnstile to excessive water in order to prevent any penetration.
- Provide your turnstile with electrical grounding connection.

# TURNSTILE USER INSTRUCTIONS

- The turnstile is designed so as to allow one person to pass each time and more than one person mustn't try to pass at the same time.
- In case of not functioning properly, avoid actions that may result in damage to the turnstile.
- In case of any malfunctioning, in order to avoid further damage to the system, should the system be taken in idle state or mustn't be used.
- Substances harmful to turnstile mustn't be used for cleaning.

The manufacturer will not accept any responsibility for any inquiry or damage resulting from incompliance with the security and safety instructions indicated above.

## T230 MOTORIZED VIP 3KTURNSTILE TECHNICAL SPECIFICATIONS

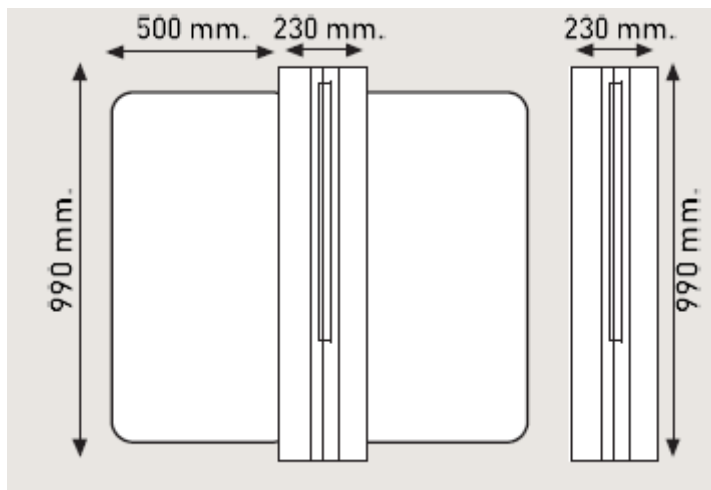

**Power** : 220V 50Hz / 30 W

**Operating Voltage** : 24 V DC +- %20

**Body Features** : Waterproof body with 1,5 mm 304 grade stainless steel

**Control System** : It is commanded by Dry Contact or any other recommended voltage. It is possible to use with all kinds of access control units or token mechanisms. Additionally, it can be commanded by RS232 and RS485 (optional).

**Pass Block** :By using 15 mm transparent plexiglass with separator.

**Locking** :It is locked by 24DC solenoid with special magnetic gear mechanism, locks when the solenoids are pulled. In emergency, the system is shut down and turnstiles provide free passing in both directions.

**Motion Control** :Bidirectional entry/exit, free control

**Arms** :14 mm, and made up of plexiglass.

**Operating Temp** : - 10 C<sup>0</sup> - + 50 C<sup>0</sup>

**Passing Signs** :Red light while the plexiglass is closed and green light while it is open (optional).

**Dimensions** :230 x 1030 x 990 mm

**Weight** :35 kg

**Accessories** :Electrical control unit, Remote unit, Button unit, Modular Platform

## **T230 MOTORIZED VIP 3KTURNSTILE SYSTEM SPECIFICATIONS**

1. The system is designed to allow free pass. When the power is turned off, the arm turns freely.
2. The parts of the turnstile carrying load and giving motion are made up of stainless steel or galvanized materials.
3. The pass is performed in a silent and smooth manner with the aid of electronic gear and smart control unit.
4. Every turnstile is designed with a control card, however, it can be modified and programmed for customer needs and wants (optional).

5. Turnstiles switch to home mode in 15 sec if there is no pass after the entry data is received (the locking time can be calibrated if needed as optional).
6. The turnstile is switched to the “emergency mode” by the manual button or any data coming from the fire alarm system. In emergency, the system is shut down and turnstiles provide free passing in both directions.
7. Turnstiles allow only one pass based on the Access type (token, card reader, button, etc.).
8. Entry data is transferred to terminal after the necessary system infrastructure.

## POWER SUPPLY

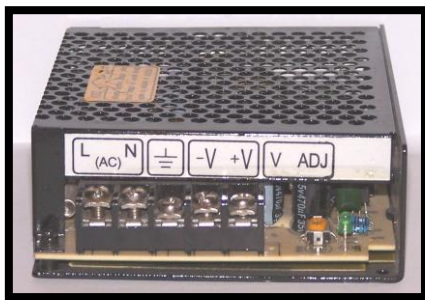

1. Do not remove the protecting seal on the power supply.
2. Please perform your operations paying attention to the warnings, electricity and safety fuse data on the protecting seal and power supply.
3. On the label placed on the power supply, the connection points are shown. Please follow the signs on the label while carrying out the connection.

**NOTE: PLEASE DO NOT PROVIDE THE POWER FROM THE CARD OR POWER SUPPLY ON THE TURNSTILE TO THE EXTERNAL EQUIPMENT. THE MANUFACTURER WILL NOT ACCEPT ANY RESPONSIBILITY FOR ANY INQUIRY OR DAMAGE RESULTING FROM INCOMPLIANCE WITH THE SECURITY AND SAFETY INSTRUCTIONS INDICATED ABOVE.**

## T230 MOTORIZED VIP 3KTURNSTILE ASSEMBLY INSTRUCTIONS

1. Select a proper location so as not to obstruct turnstile's operation.
2. Check the structure of the ground of installation site to ensure the necessary stability requirements.
3. Mark the hole places on the ground in which the turnstile will be mounted.
4. Drill the marked mounting holes by Ø10 drill bit and clean the dust inside the hole by the help of the air.
5. Fix the steel anchors to the drilled holes. If the ground is not strong, fix the steel anchors after using chemical soil mixture. (Wait 20 minutes for hardening of chemical soil mixture)
6. Pass the power and data cables which are prepared before through the hole on mounting plate.
7. Put the mounting plate on the steel anchors and after putting the washer and nuts, fix the ground.
8. You can see the pictures and drawing illustrating anchor and turnstile's mounting operation.





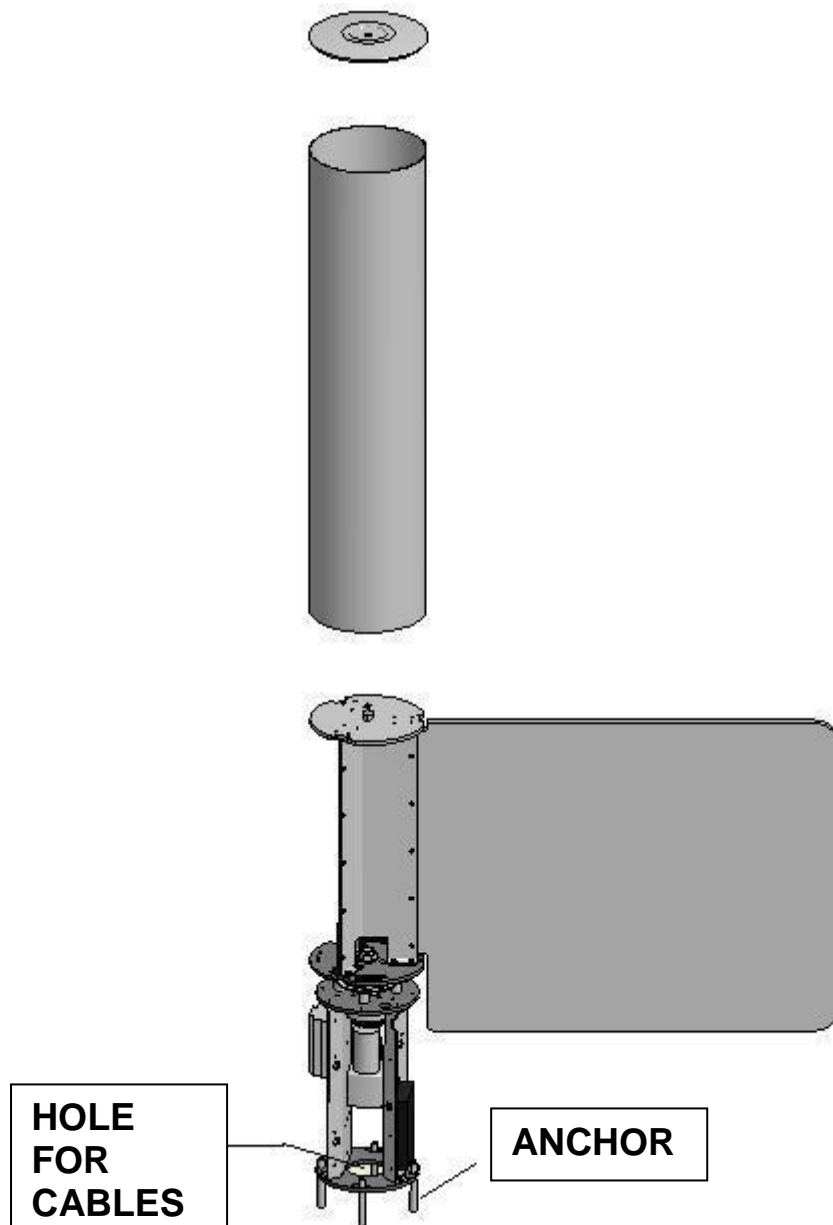

### T230 MOTORIZED VIP 3K MATERIAL LIST

<b>A</b>	<b>B</b>	<b>C</b>	<b>D</b>	<b>E</b>
M6x10 STEEL ANCHOR	M8x25 INBUS BOLT	M8 RONDELA	M8 NUT	M8 WASHER
4 pieces	4 pieces	4 pieces	4 pieces	4 pieces



## **T230 MOTORIZED VIP 3KTURNSTILE -HOW TO RUN**

**[A]** THE CONTROL IS STARTED IN 3 SEC AFTER POWER CUT.  
IF THE ARM IS IN ZERO MODE (CLOSED MODE), IT IS LOCKED AT THIS POSITION.  
IF THE ARM IS BETWEEN OPEN & CLOSED POSITION, IT MOVES IN CCW DIRECTION.  
IF THE ARM COMES TO THE CLOSED MODE, IT STOPS & LOCKS.  
IF THE ARM IS OPEN IN CCW DIRECTION, IT STOPS AND CLOSES AFTER 5 SEC.  
NOTE: IF IT IS INHIBITED IN CCW DIRECTION IN SETUP, ZERO MODE DIRECTION IS CW.

**[B]** THE BUTTONS ON THE REMOTE CONTROL;

**1)** CCW (COUNTER CLOCKWISE) BUTTON: IT IS FOR MOVING THE ARM IN ANTI CLOCKWISE DIRECTION. IF THE ARM IS CLOSED, IT OPENS IN CCW DIRECTION. IF CW IS OPEN, THE ARM IS CLOSED.

**2)** CW (CLOCKWISE) BUTTON: IT IS FOR MOVING THE ARM IN CLOCKWISE DIRECTION. IF THE ARM IS CLOSED, IT OPENS IN CW DIRECTION. IF CCW IS OPEN, THE ARM IS CLOSED.

**NOTE:** IF THE BUTTON IS PRESSED DURING OR AFTER THE ARM IS OPENED, THE ARM REMAINS OPEN. IN ORDER TO CLOSE THE ARM, PRESS THE OTHER BUTTON. IF THE ARM IS OPEN AND NOT IN IDLE MODE, IT IS CLOSED AFTER 5 SEC (TIME CAN BE CALIBRATED IN SETUP).

**3)** IDLE/CONTROLLED BUTTON: WHEN PRESSED, THE ARM IS IDLE AND IT CAN BE MOVED BY HAND. WHEN THE BUTTON IS IN NORMAL POSITION, THE EQUIPMENT IS CONTROLLABLE.

**[C]** USING SENSOR WHILE OPENING;  
IF THE SENSOR DETECTS A PERSON, THE ARM IS OPENED AFTER PRESSING THE "OPEN ARM" BUTTON.

**[D]** RED: READY / GREEN: ON WARNING LIGHT;  
AS OPENING GREEN BLINKS, WHEN OPENED GREEN IS ON.  
AS THE ARM IS CLOSING RED BLINKS, WHEN CLOSED RED IS ON.

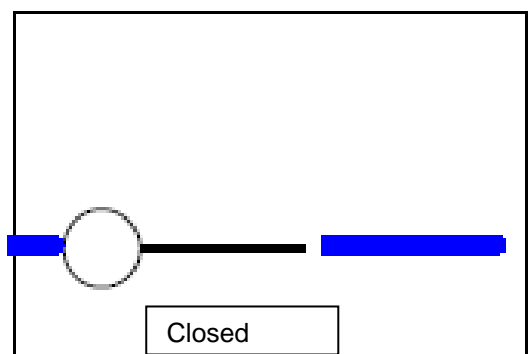
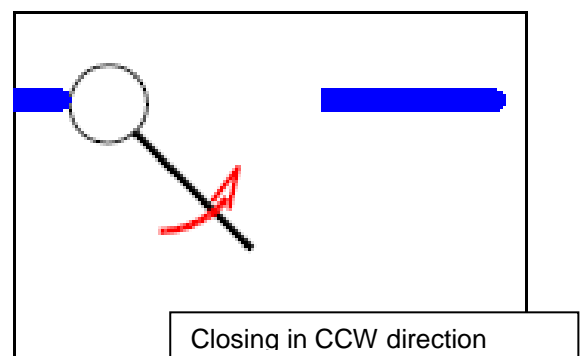
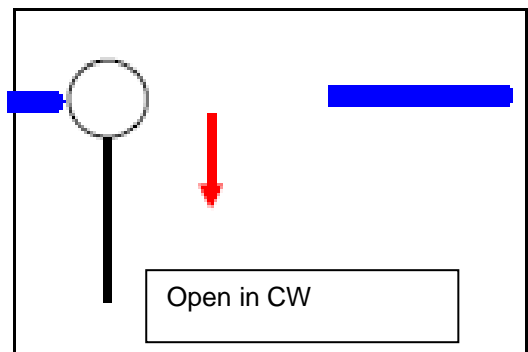
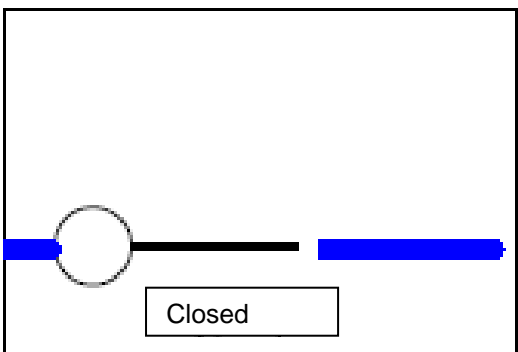
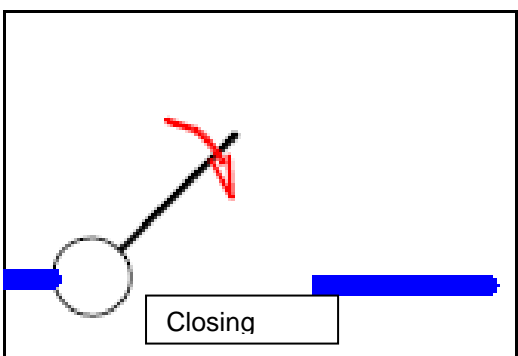
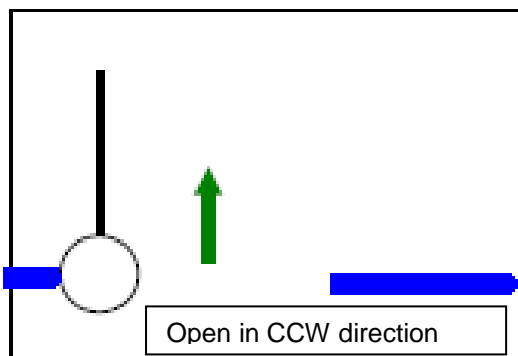
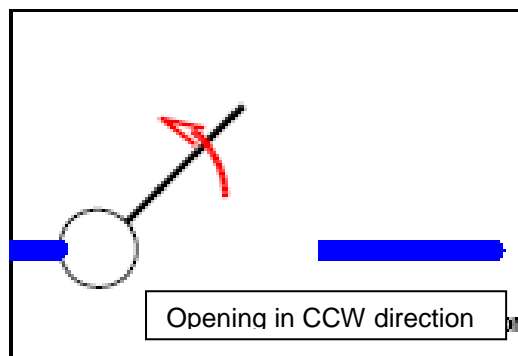
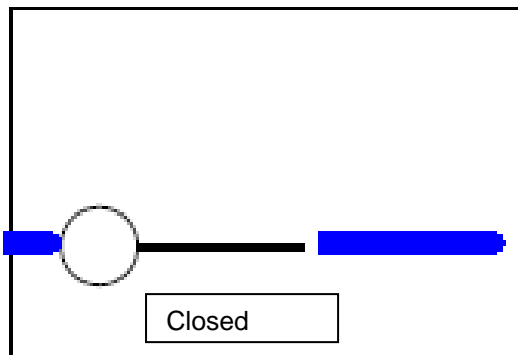

## T230 MOTORIZED VIP 3KTURNSTILE MAINTENANCE INSTRUCTIONS

1. The clothing of the turnstile must be cleaned with wet rag.
2. The connection screws of turnstile should be visually checked every 6 months.
3. Turnstile arm connection must be visually checked.

**NOTE:** Turnstile must have maintenance service by authorized service or distributors periodically. In case it is not able to contact with an authorized service or dealer, get into contact with producer firm and obtain information on periodical maintenance.

<b>T250 Electro mechanic Turnstile</b>		<b>Time</b>	<b>Operation</b>
<b>General</b>	Turnstile Plexi Bolts	12 months	<b>Control</b>
	Ground Fixing Bolts	12 months	<b>Control</b>
<b>Turnstile Mechanism</b>	Solenoids	12 months	<b>Control + Cleaning</b>
	Wheel	12 months	<b>Control + Cleaning</b>
	Carrier Shaft Nut	12 months	<b>Control</b>
	Gear Connection Bolts	12 months	<b>Control</b>
	Microswitches	12 months	<b>Control</b>
	Carrying mechanism	12 months	<b>Control + Lubrication</b>
<b>Electronic Card</b>	Electrical Connections	12 months	<b>Control</b>
	Motor Connection Cables	12 months	<b>Control</b>
	<b>PLC</b>	<b>12 months</b>	<b>Control</b>

## T230 TURNSTILE TROUBLESHOOTING

Fault	Reason(s)	Solution(s)
Although the electricity is on, the arms cannot be locked, the displays are turned off, and the turnstile is functionless.	<ol style="list-style-type: none"> <li>1. Power supply may be off or broken.</li> <li>2. Electrical fuse could be blown out.</li> </ol>	<ol style="list-style-type: none"> <li>1. Check whether the electrical cable is plugged in.</li> <li>2. Change power supply if needed.</li> </ol>
After one pass, the turnstile is not locked and it allows multiple passes.	<ol style="list-style-type: none"> <li>1. Direction sensor microswitches could be broken.</li> <li>2. Electronic card could be broken.</li> <li>3. Magnetic gear could be broken.</li> </ol>	<ol style="list-style-type: none"> <li>1. Replace microswitches.</li> <li>2. Replace electronic card.</li> <li>3. Check the magnetic gear connections and replace if broken.</li> </ol>
Although the electricity is on the arms are turning freely.	<ol style="list-style-type: none"> <li>1. Solenoid could be broken or there may be connection defects.</li> <li>2. Electronic card could be broken.</li> </ol>	<ol style="list-style-type: none"> <li>1. Replace solenoid and also check the connections.</li> <li>2. Replace electronic card.</li> </ol>
The turnstile does not send info after pass.	<ol style="list-style-type: none"> <li>1. Cycle sensor micro switches could be broken or there may be connection defects.</li> <li>2. There may be defects in the cable transferring data.</li> <li>3. Electronic card could be broken.</li> </ol>	<ol style="list-style-type: none"> <li>1. Replace microswitches and check the connections.</li> <li>2. Check the cables carrying data.</li> <li>3. Replace electronic card.</li> </ol>
Turnstile arms are giving noise due to friction while turning.	The main mechanism may have been hit and/or the nut could be loosened up.	Tighten the nut. If that is not the case, replace the entire mechanism.
The entry and exit speeds are different.	The turnstile may not be mounted in a level ground.	The turnstile should be mounted on a level ground and this operation should be checked by water balance.
The turnstile is not standing at 90 degrees, and it is exceeding the level.	Switch positions may be tilted due to hit or switches could be broken due to hits.	<ol style="list-style-type: none"> <li>1. Calibrate the switch positions.</li> <li>2. Replace the switches.</li> </ol>

Notes:

—

—

—

—

—

—

—

—

—

—

—

—

—

—

—

—

—

—

—

—

—

—

—

—