

MAKIM Machinery Technologies Co.

# T200 Turnstile

---

## Operation and Maintenance Manual

**Revision History:**

**09.02.2009**

**MAKIM reserves the right to make changes at any time at this document, related product and product group without any notice. All rights reserved.**

<b>Before You Start .....</b>	<b>3</b>
<b>T200 Turnstile System Technical Specifications .....</b>	<b>4</b>
<i>Dimensions: .....</i>	<i>6</i>
<b>Modules .....</b>	<b>7</b>
<i>T200_A Turnstile Block Diagram:.....</i>	<i>7</i>
<i>BM32 Turnstile control module:.....</i>	<i>7</i>
<i>Keypad: .....</i>	<i>7</i>
<i>Programming:.....</i>	<i>8</i>
<i>Input and Output Ports: .....</i>	<i>9</i>
<i>BM 29 Indicator Cards.....</i>	<i>13</i>
<i>Other Equipments .....</i>	<i>13</i>
<i>Turnstile Electrical Circuit Diagram:.....</i>	<i>14</i>
<b>T200 Turnstile Mechanic Mounting Instructions .....</b>	<b>15</b>
<i>Mounting Drawing for T200 .....</i>	<i>15</i>
<i>T200 Material List .....</i>	<i>15</i>
<b>T200 Turnstile Maintenance Instructions .....</b>	<b>16</b>
<b>Turnstile Troubleshooting .....</b>	<b>17</b>

## Before You Start

Thank you for purchasing T200 Electro-mechanic Turnstile. Please, carefully read the instructions contained in this manual for a long and smooth operation of the turnstile and keep the manual for future references.



### TURNSTILE SAFETY INSTRUCTIONS

- It is recommended to read all safety and maintenance instructions before installing and using the turnstile.
- Read the manual, before operating the turnstile.
- Do not open the turnstile, due to safety precautions. Any repairment must be done only by authorized services. Modifications made by user may result in danger for the turnstile and people.
- Do not operate damaged turnstiles and call an authorized service immediately.
- Comply with the power and voltage values specified in the technical specifications of turnstile.
- Comply with the operating temperature range specified in the technical specifications of turnstile.
- Check the power supply and control the card connections before re-energizing the turnstile afterwards any maintenance or damage.
- Use certificated spare parts and accessories approved and allowed by the producer.
- In any problem, cut off the electrical connections of the turnstile and call an authorized service.
- During the cleaning and maintenance, cut off the electrical connections. Otherwise damage to the parts may result.
- Use wet rag for cleaning.
- Keep the turnstile away from over heated or fire environment. Over heat may result in a damage to the turnstile.
- Do not use the turnstile in high magnetic areas.
- Do not expose the turnstile to excessive water in order to prevent any penetration.
- Provide your turnstile with electrical grounding connection.

### TURNSTILE USAGE INSTRUCTIONS

- The turnstile is designed so as to allow one person to pass each time and more than one person mustn't try to pass at the same time.
  - In case of not functioning properly, avoid actions that may result in damage to the turnstile.
  - In case of any malfunctioning, in order to avoid further damage to the system, should the system be taken in idle state or mustn't be used.
  - Substances harmful to turnstile mustn't be used for cleaning.
- The manufacturer will not accept any responsibility for any inquiry or damage resulting from incompliance with the security and safety instructions indicated above.

## T200 Turnstile System Technical Specifications

Power	220 V AC or 24 V DC 30W
Operating Voltage	24 V DC +- %20
Body Features	Waterproof body with 1,5mm 304 grade stainless steel
Outdoor Use	Our turnstiles are designed for outdoor use.
Pass Block	With controlled tripod arms positioned with at 120 <sup>0</sup> degrees
Arms	Polished stainless pipe, Ø32x2mm. Each arm can be demounted.
Tripod Lock	It is locked with 24DC solenoids, locks when the solenoids are pulled. In emergency, the system is shut down and turnstiles provide free passing in both directions.
Motion Control	When the cycle starts to one direction, the reverse is blocked and after a half turn the rest of the cycle is completed, automatically and smoothly by a hydraulic shock absorber.
Operating Temp	- 20 C <sup>0</sup> - + 70 C <sup>0</sup>
Dimensions	200x840x1085 mm
Weight	45 kg
Optional Accessories	Electronical control unit, Remote unit, Button unit, Moduler Platform
Control	It is commanded by TTL, CMOS, and Dry Contact for pass triggering. Additionally, it can be commanded by RS 232, RS422, and RS485 through PC with BM33 module. It is possible to command additional warning/caution devices that can be mounted on Turnstile through 3 extra dry contact relays when used with BM33 module. It is possible to use with all kinds of Access control units.
System	Micro Controller was designed based on Modular structure. Turnstile is a combination of the modules that fit for your requirements. Thereby, in comparison with complicated systems, it eliminates the additional costs to be paid for the modules you do not require as well as avoiding the defects from the parts which do not belong to system and the extra power consumption used by them. When used with PC, if required, it is possible to follow how many passes were made through the turnstile. It was designed so as to operate bidirectional. If required, it can be transformed so as to operate bidirectional or to a free turnstile (only with setting).
Emergency Mode	When the power supply of the turnstile is cut, passing becomes free in both directions. When the free button is pressed, passing becomes free in both directions. In models with retractable arms, when the panic button is pressed, arms drop down automatically and passageway is opened entirely.

Passage Signs	There are indicators with two-colored lights on both sides at entry and exit.
Indicators	On stand by state, it indicates that the turnstile is ready with continuous "green arrow". Flashing green arrow in passing direction indicates free passing and continuous red "X" sign in opposite direction indicates that passing though the opposite direction is opened and waiting is required. An audio alarm indicates that passing is opened at the time of passing. Audio alarm will accelerate and indicate lapse of time close to end of the time given for passing.
Quality System	Manufacture process of our turnstiles is assured under ISO-9001-2000 quality system. Compliance with relevant EN, DIN and TSE standards are based on for all kinds of product used in production.
Application	Our applications include Subway systems particularly in Istanbul and Ankara, Istanbul City Line and Sea Bus price payment systems, Personnel Continuity Control systems, cafeteria, pool etc. amusement places price payment systems, entrance systems of various fair and organizations.
Guarantee Period	2 Years

**Dimensions:**

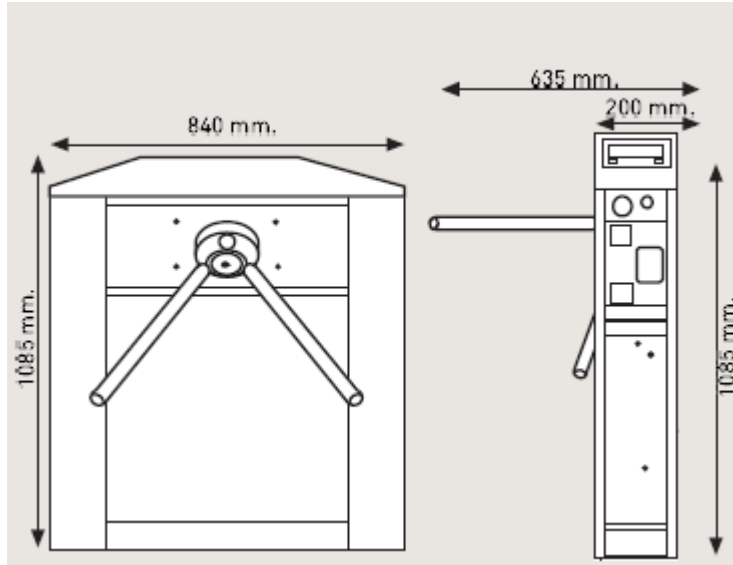

Figure 1. Dimensions of T200 Turnstile

## Modules

### T200 Turnstile Block Diagram:

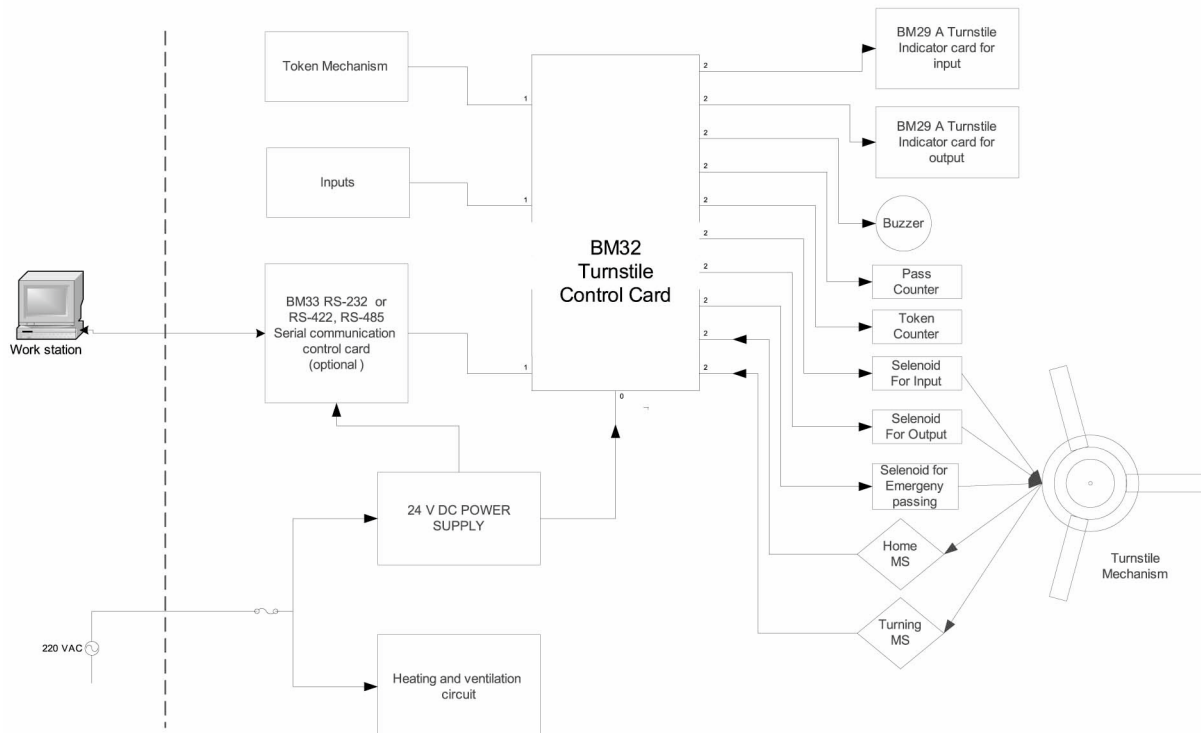

Figure 2. Turnstile Block Diagram

### BM32 Turnstile control module:

Manufactured with reliable 8051 micro-controller technology, it has two main modes as operating and programming. Operating mode can be programmed according to the list below.

#### Keypad:

Input, output and mode keys are available on BM 32 card.

Programming mode or operating mode can be selected by the mode key.

Input and output keys provide entry and exit right while the turnstile is in "Operating mode".

In programming mode, it is used for adjustment of turnstile as indicated the table above.

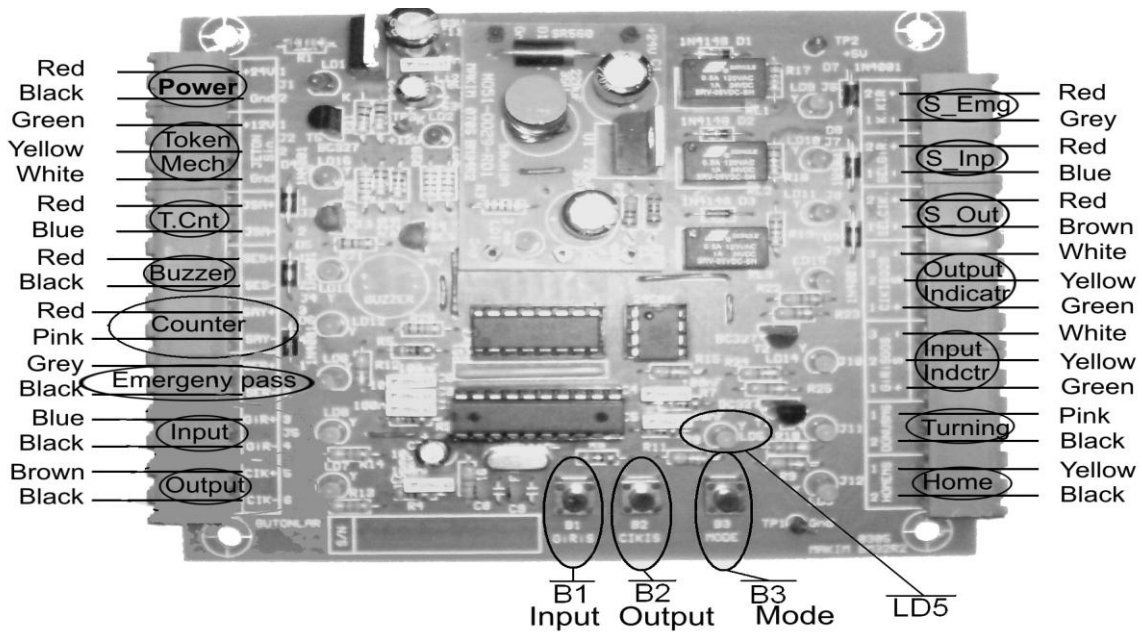

Figure 3. BM32 Card Connectors, Cable Colors, and Keypad

Operating Mode	Input	Output	Required key combination for programming
0	Locked	Locked	Press M and simultaneously press G or C until input and output displays turn to red (until LD14 and LD15 LEDs are turned off)
The following modes are written assuming that the operating mode of the turnstile is 0.			
1	Controlled Passing	Controlled Passing	M+G+G+C+C+M
2	Locked	Controlled Passing	M+C+C+M
3	Controlled Passing	Locked	M+G+G+M
4	Free	Controlled Passing	M+G+C+C+M
5	Controlled Passing	Free	M+G+G+C+M
6	Locked	Free	M+C+M
7	Free	Locked	M+G+M
9	Free	Free	M+G+C+M

**Programming:**

For entering and exiting to programming mode, Mode Key is used.

In Programming Mode:

- Entry key changes the passing right among “Free”, “Controlled passing” and “Locked”, respectively.
- Exit key, changes the passing right among “Free”, “Controlled passing” and “Locked” respectively.
- In “Free” state, indicator is green, and no buzzer audio.
- “Controlled Passing” state, indicator is green and buzzer alarms.
- In “Locked” state the indicator is red.
- Use mode Key to exit from programming mode.

When not in programming mode:



- Entry key gives entry right,
- Exit key gives exit right.

**Input and Output Ports:**

**+24 VDC supply:**

It connects via J1 connector. All voltage levels necessary for circuit is obtained from this source.

**Token Signal and Token Counter Ports:**

Token mechanism connects via J2 connector. J2 provides 12 V supply voltage required for Token mechanism. The “Token was dropped” signal which is produced by the mechanism is taken from this connector.

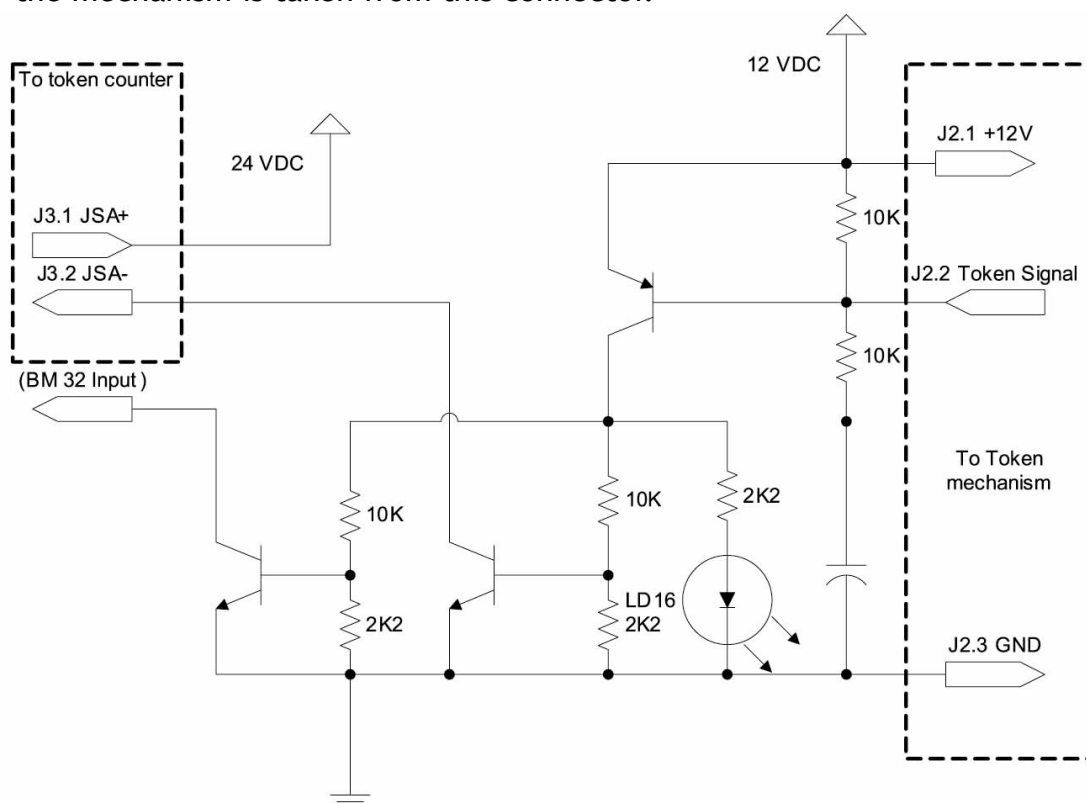

Figure 4. Token Mechanism and Token Counter Connection Equivalent Circuit

It produces one “passing right to entry side” signal in return for “token was dropped” signal and the signal required for increasing the value on the token counter by one level.

Avoid drawing current more than 0 mA instantly and 100 mA continuously from the J3.2 JSA connector.

**“Free”, “Authorize entry” and “Authorize exit” Inputs:**

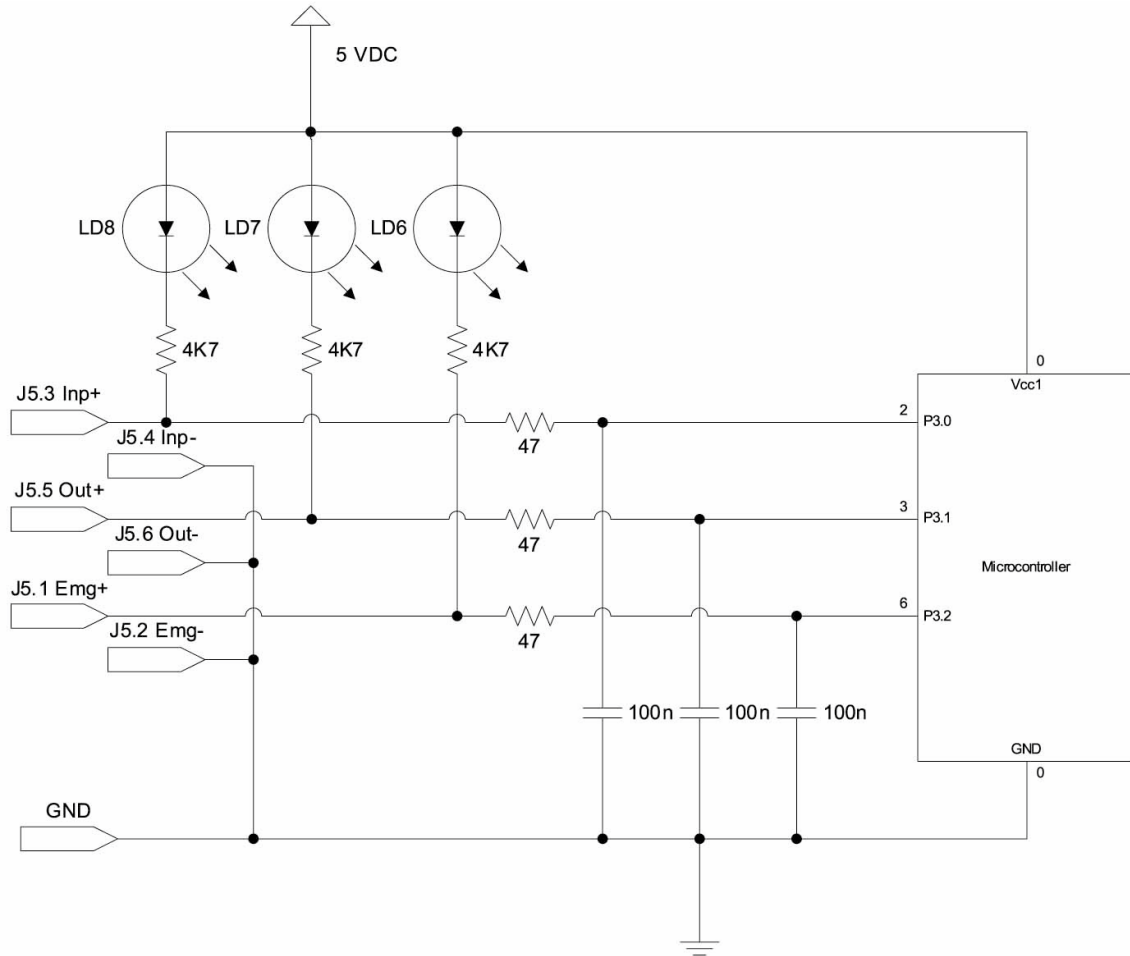

Figure 5. Input Output and Free Ports Equivalent Circuit

As indicated in the diagram, turning the ports to low position or to GND by dry contact is enough to trigger the input.

**Home and Turn Microswitch Inputs:**

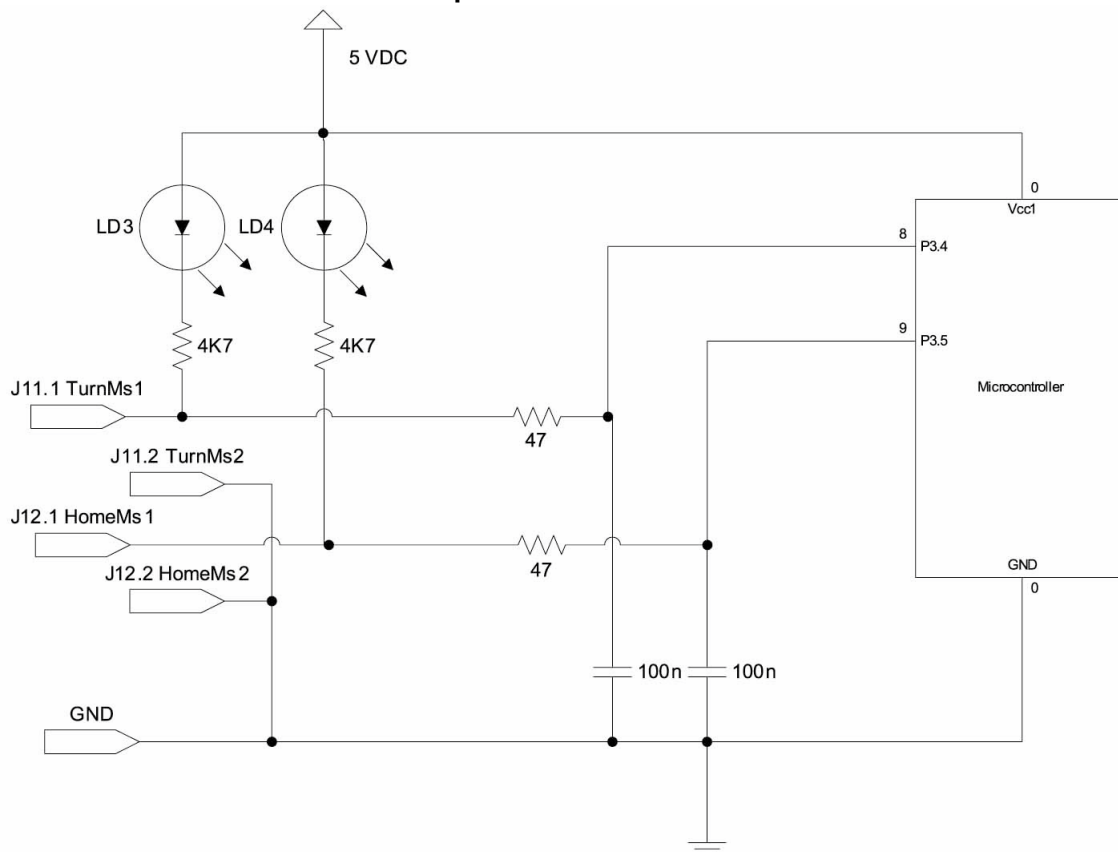

Figure 6. Home and Turn Microswitches Connection Equivalent Circuit

NO contacts of the Microswitches on the mechanism are connected via BM 32 card's TurnMS and HomeMS inputs.

**“Passing Counter”, “Audio” and “Indicator” Control Outputs:**

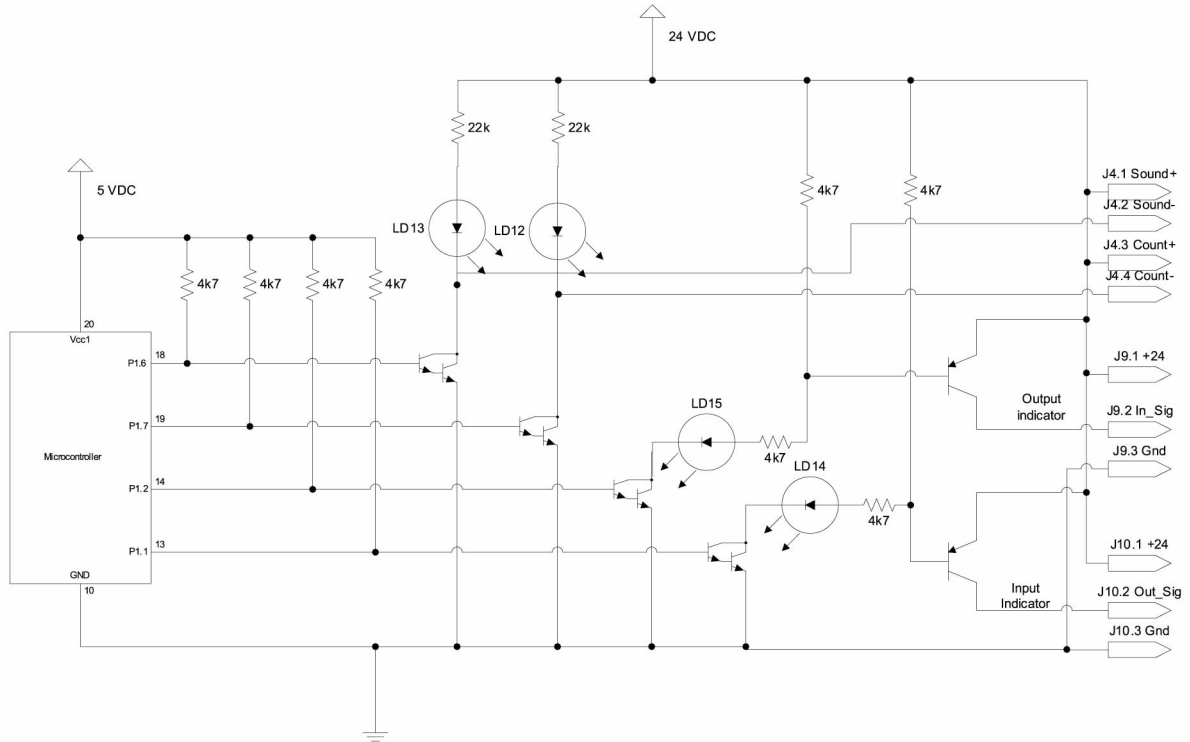

Figure 7. Passing Counter, Audio and Indicator Ports Equivalent Circuit

Passing counter, audio, and indicators are open collector type outputs.

**“Solenoid” Control Outputs:**

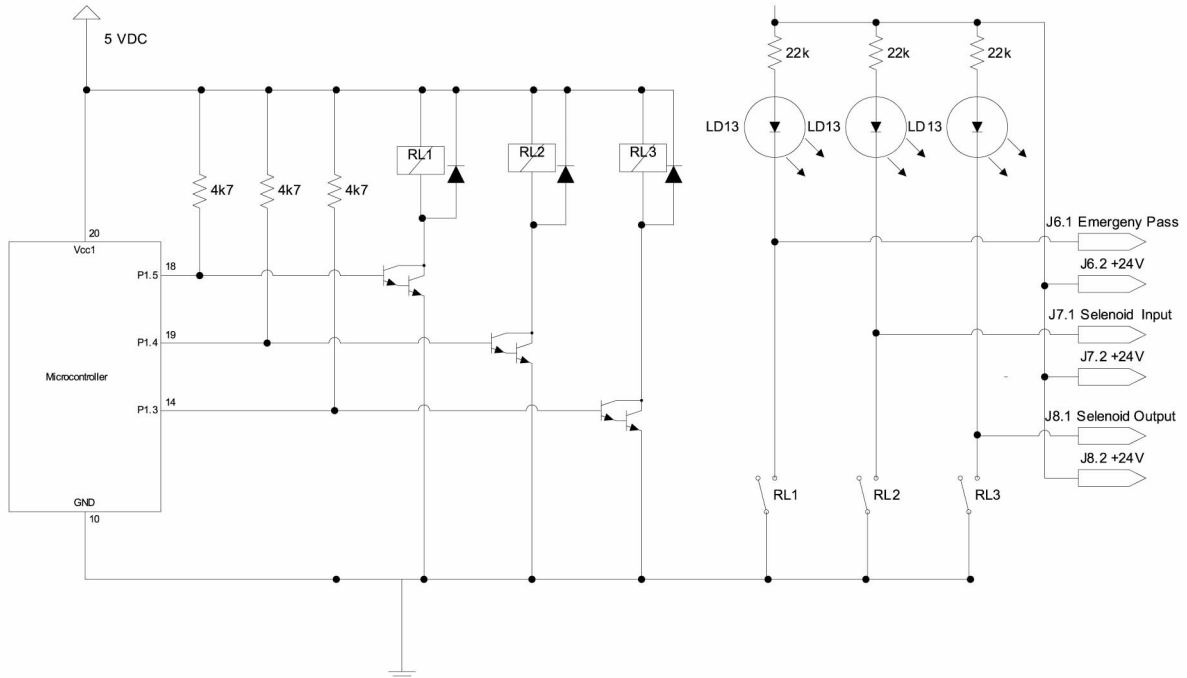

Figure 8. Solenoid Ports Equivalent Circuit

Solenoid outputs are dry contact and normally in open relay type.

### BM 29 Indicator Cards

Connector includes 24 V Supply pin, GND pin, and Signal pin. The green allow or red allow flashes according to the information coming from the Signal pin under power supply.

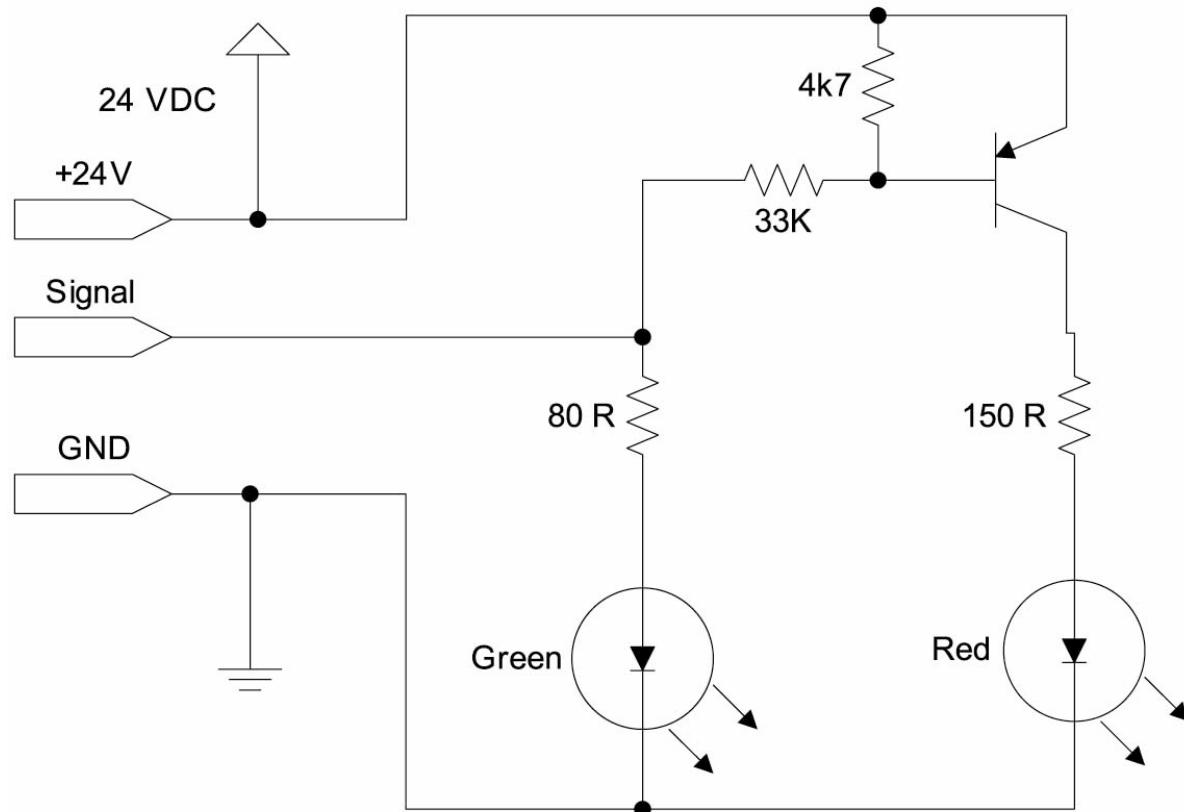

Figure 9. BM29 Equivalent Diagram

### Other Equipments

#### Solenoids

In T-Mek A models, Solenoids draw 300 mA continuous (Constant) current with 24 V supply.

In T-Mek B models Solenoids draw 1500 mA continuous (constant) current with 24 V supply.

#### Counters:

24 V Mechanic or Electronic Counter can be used.

#### Power Supply:

Model Mean Well trade mark 25 W, 24V, S-25-24 power supply is used.

On the right: The Picture of the power supply

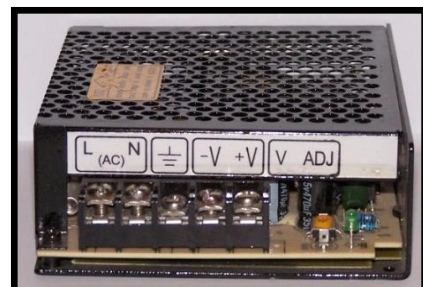

**Heating and Air Circulation Circuit:**

For air circulation 90-90 fan is used. It operates when the temperature of the turnstile heated over 35 °C. For heating, 200 W heater is used. When the internal temperature of turnstile is below 10°C, it starts to operate automatically with fan. The heating and air circulation circuits can be set by thermostat, it can be set to different degrees depends on demand.

**Fuse:**

It is protected by 2 A automatic fuse.

**Turnstile Electrical Circuit Diagram:**

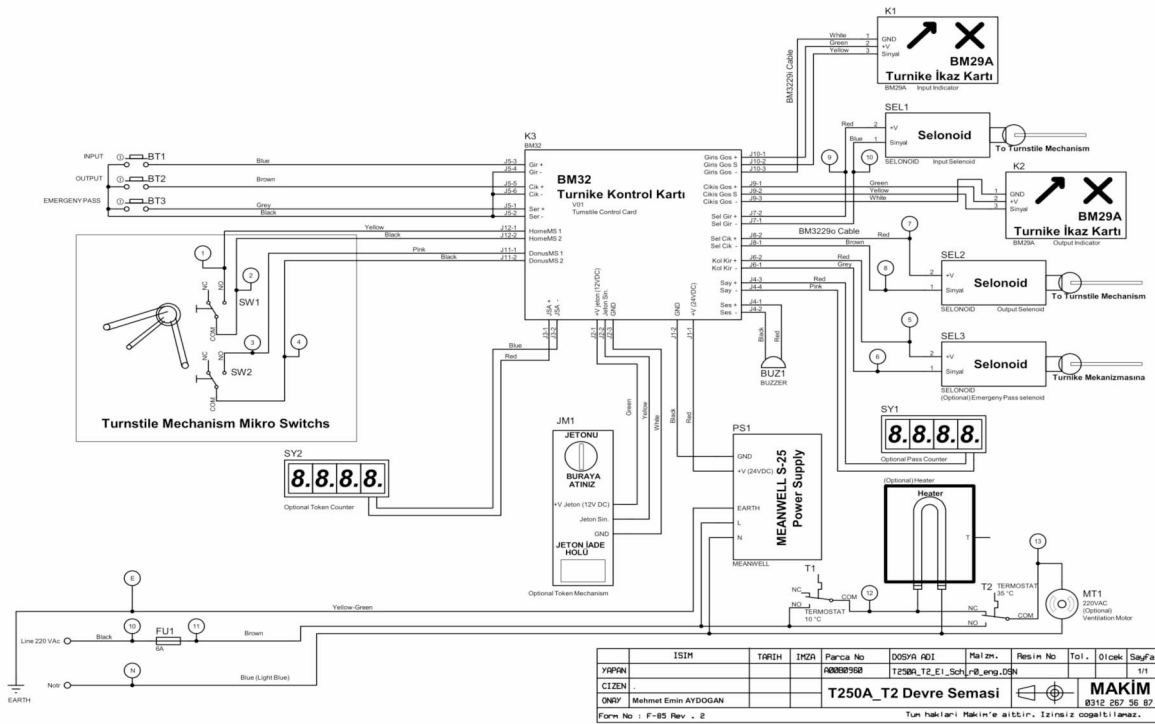

Figure 10. Circuit Diagram

# T200 Turnstile Mechanic Mounting Instructions

1. Select a proper location so as not to obstruct turnstile's operation.
2. Check the structure of the ground of installation site to ensure the necessary stability requirements.
3. Mark the hole places on the ground in which the turnstile will be mounted.
4. Drill the marked mounting holes by  $\varnothing 10$  drill bit and clean the dust inside the hole by the help of the air.
5. Fix the steel anchors to the drilled holes. If the ground is not strong, fix the steel anchors after using chemical soil mixture. (Wait 20 minutes for hardening of chemical soil mixture)
6. Pass the power and data cables which are prepared before through the hole on mounting plate.
7. Put the mounting plate on the steel anchors and after putting the washer and nuts, fix the ground.
8. After putting the turnstile on the fixed mounting frames, screw the bolts connecting the turnstile and mounting plate to each other.

## Mounting Drawing for T200



Figure 11. Mounting Drawing for T200

## T200 Material List

M10x85 Steel Anchor	M10x20 Inbus Bolt	M10 Washer
4 pieces	4 pieces	4 pieces

## T200 Turnstile Maintenance Instructions

1. The clothing of the turnstile must be cleaned with wet rag.
2. The connection screws of turnstile should be visually checked every 6 months.
3. Turnstile arm connection must be visually checked.

NOTE: Turnstile must have maintenance service by authorized service or distributors periodically. In case it is not able to contact with an authorized service or dealer, get into contact with producer firm and obtain information on periodical maintenance.

<i>T200 Electro mechanic Turnstile</i>		<i>Time</i>	<i>Operation</i>
<b>General</b>	Turnstile Arm Torque Bolt	12 months	<b>Control</b>
	Ground Fixing Bolts	12 months	<b>Control</b>
<b>Turnstile Mechanism</b>	Solenoids	12 months	<b>Control + Cleaning</b>
	Springs	12 months	<b>Control</b>
	Hydraulic Shock Absorber	12 months	<b>Control</b>
	Hydraulic Shock Absorber	36 months	<b>Renewing the oil</b>
	Mechanism Connection Cable	12 months	<b>Control</b>
	Components	12 months	<b>Control + Lubrication</b>
<b>Electronic Card</b>	Electrical Connections	12 months	<b>Control</b>
	Indicator Cards	12 months	<b>Control + Cleaning</b>
	<b>Electronic Cards</b>	<b>12 months</b>	<b>Control</b>



## Turnstile Troubleshooting

Fault	Reasons	Solution
Although the electricity is on, the arms cannot be locked, the displays are turned off, and the turnstile is functionless.	<ol style="list-style-type: none"> <li>1. Power supply may be off or broken.</li> <li>2. Electrical fuse could be blown out.</li> </ol>	<ol style="list-style-type: none"> <li>1. Check whether the electrical cable is plugged in.</li> <li>2. Change power supply if needed.</li> </ol>
After one pass, the turnstile is not locked and it allows multiple passes.	<ol style="list-style-type: none"> <li>1. Direction sensor microswitches could be broken.</li> <li>2. Electronic card could be broken.</li> </ol>	<ol style="list-style-type: none"> <li>1. Replace microswitches.</li> <li>2. Replace electronic card.</li> </ol>
Although indicators and buzzer work, the turnstile does not allow pass.	<ol style="list-style-type: none"> <li>1. There may be a cable preventing the solenoid to open.</li> <li>2. Electronic card could be broken.</li> <li>3. Solenoid could be broken or there may be connection defects.</li> </ol>	<ol style="list-style-type: none"> <li>1. The problematic cable is fixed.</li> <li>2. Replace electronic card.</li> <li>3. Replace solenoid and also check the connections.</li> </ol>
Although the electricity is on the arms are turning freely.	<ol style="list-style-type: none"> <li>1. Solenoid could be broken or there may be connection defects.</li> <li>2. Electronic card could be broken.</li> </ol>	<ol style="list-style-type: none"> <li>1. Replace solenoid and also check the connections.</li> <li>2. Replace electronic card.</li> </ol>
The turnstile does not send info after pass.	<ol style="list-style-type: none"> <li>1. Cycle sensor micro switches could be broken or there may be connection defects.</li> <li>2. There may be defects in the cable transferring data.</li> <li>3. Electronic card could be broken.</li> </ol>	<ol style="list-style-type: none"> <li>1. Replace microswitches and check the connections.</li> <li>2. Check the cables carrying data.</li> <li>3. Replace electronic card.</li> </ol>
Turnstile arms are giving noise due to friction while turning.	The oil within the rotor wheels could be dirty or runs out.	Put WD-40 oil into the rotor wheels to make them work.

<p>In winter or summer turnstiles do not operate smoothly.</p>	<p>Due to the changes in temperature, the dumper oil may not work properly.</p>	<p>Choose the wanted calibration smoothness using the cap screw behind the dumper.</p>
<p>Arms remain crosswise after pass and they do not return to initial position.</p>	<ol style="list-style-type: none"> <li>1.The spring in the mechanism may be loosen up.</li> <li>2.Hydraulic dumper or its calibration may be broken.</li> </ol>	<ol style="list-style-type: none"> <li>1.The spring is adjusted or replaced.</li> <li>2. Hydraulic dumper setting is adjusted with the help of the cap screw behind the dumper or replaced.</li> </ol>
<p>Although the pass signal is given, the turnstile does not allow passing.</p>	<ol style="list-style-type: none"> <li>1.There may be problems in the signal sender (card reader, remote control, button) or its connections.</li> <li>2. Electronic card could be broken.</li> <li>3.Solenoid could be broken.</li> <li>4.Lock pins could malfunction.</li> </ol>	<ol style="list-style-type: none"> <li>1.Replace the signal sender and check the connections.</li> <li>2. Replace electronic card.</li> <li>3.Replace the solenoid.</li> </ol>
<p>The turnstile allows multiple passes continuously.</p>	<ol style="list-style-type: none"> <li>1.Solenoid could be broken or its cables may be unplugged.</li> <li>2.Lock pins could malfunction.</li> <li>3. The turnstile could be set to free Mode to operate in one direction.</li> </ol>	<ol style="list-style-type: none"> <li>1.Replace the solenoid and check the cables.</li> <li>2.Set the turnstile to the wanted Mode.</li> </ol>



